

Input data

System of measurement		Metric
Input type		Coupling for electric motor
Input speed	[rpm]	1400
Output speed	[rpm]	14
Ratio (i=)		100
Frequency	[Hz]	50
Input options		IEC
Requested input power	[kW]	0.37
Service factor		1.3

Output data

Gear unit	CM 075 U 100 71B5 M1	
------------------	-----------------------------	--

Type		CM - Wormgearboxes
Size		075
Ratio (i=)		100
Input flange		B5
Mounting position		M1
Input speed	[rpm]	1400
Output speed	[rpm]	14
Rated output torque	[Nm]	141.34
Service Factor		1.3
Efficiency		0.56

Gear unit configuration

Frame dimensions		METRIC
Output shaft		Hollow output shaft
Fixing		Universal
Mounting position		M1

Output radial and axial loads

Output radial load	[N]	6700
--------------------	-----	------

Electric motor coupling

Size		712-4
Poles n.		4
Power	[kW]	0.37

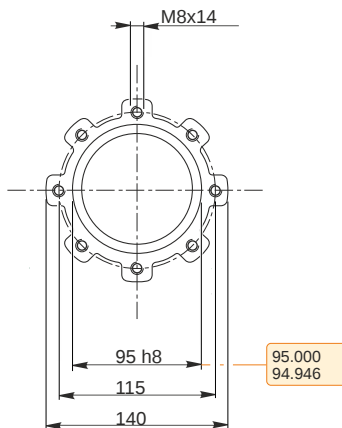
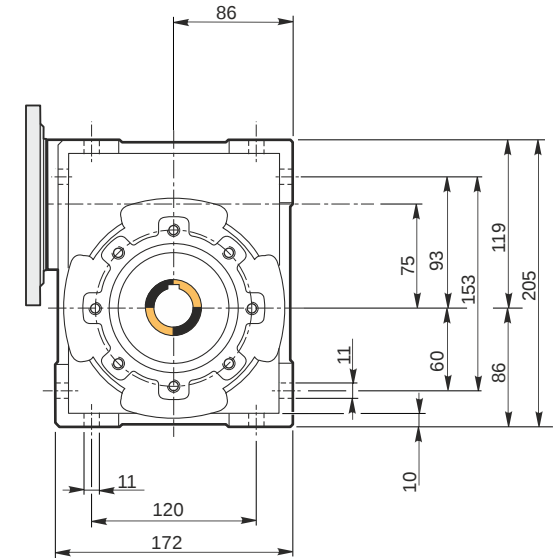
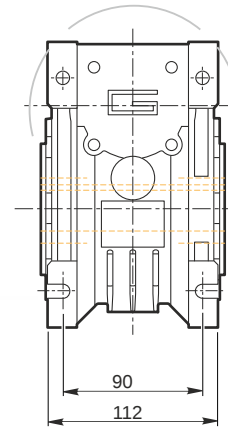
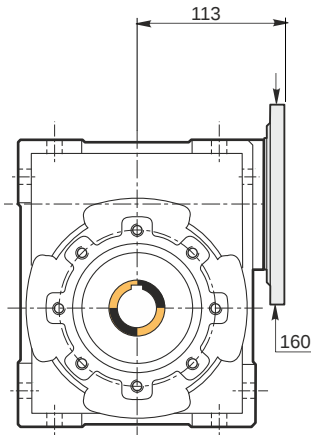

Hollow output shaft

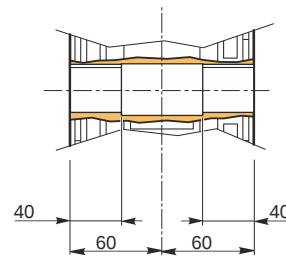
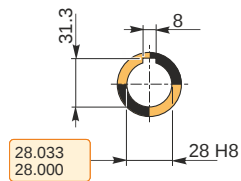

Mounting positions

M1(B3)

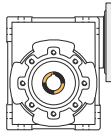

M2(V6)

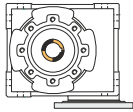

M3(B8)

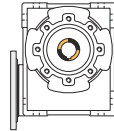

M4(V5)

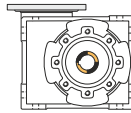

M5(B7)

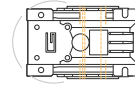

M6(B6)

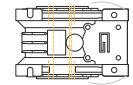

Lubricant type: this gear unit is delivered life lubricated



Oil quantity [litres]

Direction of rotation

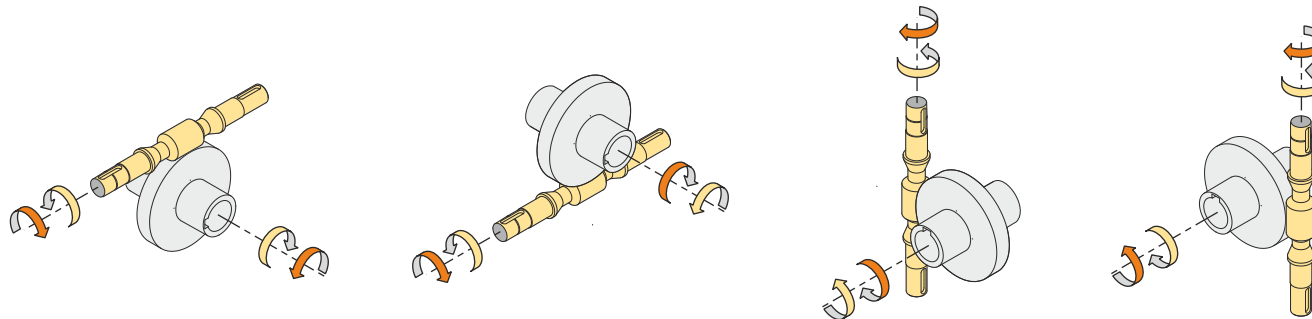

Weight

Gear unit [kg] 9

Gearing data

Number of starts 1
Lead angle 2° 40'
Pressure angle 20°

Backdriving

Static self-locking
No back-driving
Low dynamic back-driving